

Portrait

Specifications



The Portrait is a first-of-its-kind, all-in-one, touch and motion-based standing kiosk. It features a 55” 4K Ultra HD display and industry-leading touch technology from 3M™ with support for 80 touch points and the option for an integrated Microsoft™ Kinect® Sensor. The Portrait is equipped with a powerful integrated Intel™ i7 quad core computer, the latest NVIDIA™ discrete graphics cards, and single push-button power.





The Portrait's beautiful design is also incredibly tough. Its sleek lines are forged out of aircraft-grade aluminum and covered with a durable powder coat. The Portrait is quality-built in the USA, and ships as a complete, turnkey system with lockable, push-button operation. Just plug it in and turn it on. It doesn't require a technician or any special installation setup. All of Ideum's hardware is backed by a three-year manufacturer's warranty.

55"

WEIGHT
240 LBS / 109 KG

SHIP WEIGHT
500 LBS / 227 KG

W/ TRAVEL CASE
532 LBS / 241 KG

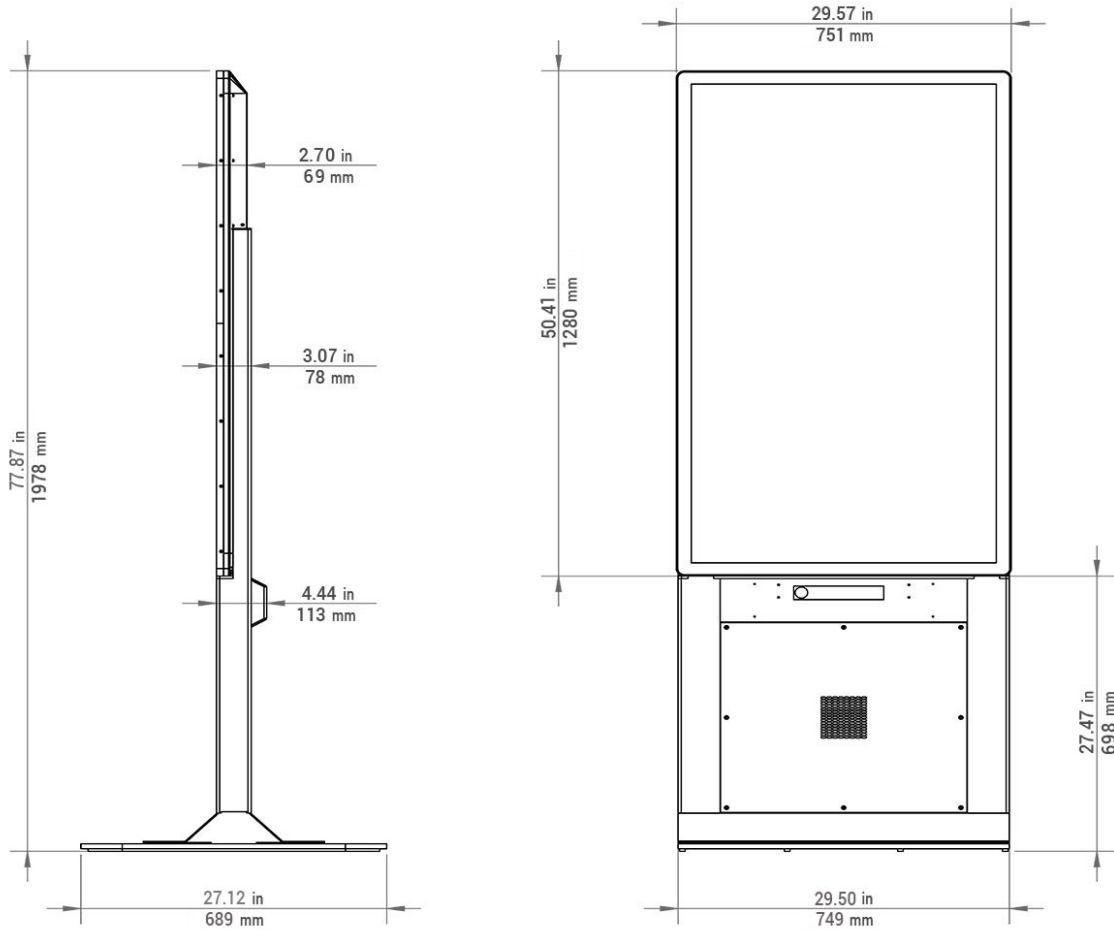

Interactive Display

- 3M™ projected capacitive touch system
- 4K UHD (3840x2160) LED LCD display
- ±5ms touch response time
- 55" diagonal, strengthened, anti-stiction, 4mm glass surface
- 80 touch points with palm rejection
- Two 10W integrated speakers

Integrated PC System

- Single push-button power
- Custom lockable enclosure
- Windows 10 (default), 8.1, or 7
- Universal 110-240V power system

STANDARD

- Intel Core i7-6700K 4.2GHz processor
- GTX 1070 8GB DDR5 NVIDIA graphics card
- Micron M600 512GB SSD
- 16GB 2133MHz DDR4 RAM

PERFORMANCE

- Intel Core i7-6700K 4.2GHz processor
- GTX 1080 8GB DDR5X NVIDIA graphics card
- Dual Micron M600 512GB SSD
- 32GB 2133MHz DDR4 RAM

Connectivity

- Microsoft™ Kinect® Sensor w/PC connector & adjustable housing (optional)
- WiFi 802.11 a/b/g/n, Ethernet, Bluetooth 4.0, RFID
- Wireless keyboard with integrated trackpad
- Direct access via USB ports
- Audio output via 1/8" audio jack
- HDMI Output (PC)

About Ideum

Ideum is a creative company based in Corrales, New Mexico. We offer exhibit design and software development services to museums, nonprofits, and socially responsible companies. Please contact us at (505) 792-1110 ext.1 or toll free in the US and Canada (855) 898-6824, use our online inquiry form, or email us at sales@ideum.com. Our multitouch products are sold domestically and internationally.

Multitouch Authoring



Ideum multitouch products include a free, lifetime license of GestureWorks 2.

GestureWorks 2 is a multitouch authoring solution that works with C++ and Unity3D. It has nine basic built-in gestures but supports hundred more using the extensible Gesture Markup Language. Licenses include ticketed, timely support (one year is included free*) and free upgrades for life. More information can be found at: gestureworks.com

WARRANTY & SUPPORT

Our products are custom built with only the highest-quality components available and are designed to last. We back all of our hardware with a three-year warranty. The same people who design and build our systems provide our timely support.

**Support hours provide dedicated time to troubleshoot any issues that may pertain to our software. Support hours are valid for the first year of purchase only. Additional annual support packages can be purchased as needed at an additional price. However, the Pro and Site Licenses are lifetime licenses. Please see our License Agreement for full details: <http://gestureworks.com/legal>*

IMPORTANT NOTICE TO PURCHASER: Specifications are subject to change without notice. Ideum hardware and software are warranted from the ship date to the period stated in the warranty. Please note that under Ideum's warranty, Ideum has no obligation for any hardware product that is modified or damaged through misuse, accident, neglect, or subsequent integration, service, or tampering, by anyone other than Ideum or an Ideum-approved entity or individual. Ideum makes no additional warranties, express or implied, including but not limited to any fitness for a particular purpose. The User is responsible for determining whether Ideum hardware products or software are fit for the

User's particular purpose. If the hardware product or software are proven not to have met Ideum's warranty, then Ideum's sole obligation and User's and Purchaser's exclusive remedy, will be, at Ideum's option, to repair or replace the product or refund its purchase price. Ideum shall not be liable in any action against it in any way related to the hardware products or software for any loss or damages, whether non-specified, direct, indirect, special, incidental or consequential (including downtime, loss of profits or goodwill) regardless of the legal theory asserted. Please see our full warranty for complete details.